

SOLIDRILL BR33 HAMMER

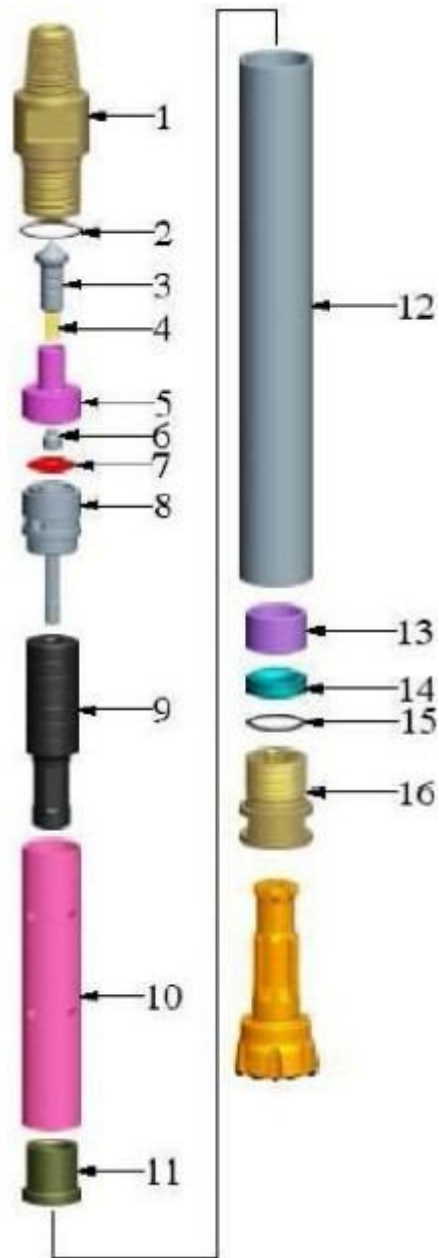

ITEM	PART NAME	PART NO
1	Top Sub	SD-30-01
2	O-Ring For Top Sub	SD-30-02
3	Check Valve	SD-30-03
4	Spring	SD-30-04
5	Top Valve	SD-30-05
6	Valve Centralizer	SD-30-06
7	Disc Valve	SD-30-07
8	Bottom Valve	SD-30-08
9	Piston	SD-30-09
10	Liner	SD-30-10
11	Guide Bush	SD-30-11
12	Wear Sleeve	SD-30-12
13	Split Bush	SD-30-13
14	Bit Retainer Ring	SD-30-14
15	O-Ring For Bit Retainer Ring	SD-30-15
16	Drive Sub	SD-30-16

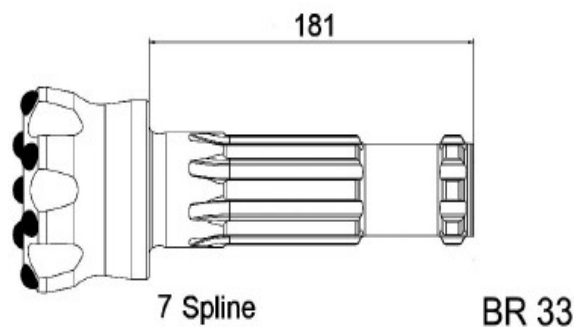

HAMMER SPECIFICATIONS		AIR CONSUMPTION			
		PSI	BAR	CFM	M3/min
WEIGHT	23.5 kg	150	10,3	95	2,6
LENGTH	835 mm	200	13,8	150	4,3
HAMMER DIAM. OUTSIDE	82 mm	250	17,2	210	5,9
MAX WORKING PRESSURE	24 bar	300	20,7	280	7,8
THREAD	RD50 Male	350	24,1	325	9,2